

The World Leading Provider of High Pressure Equipment for Research and Industry since 1945!

1.5002

MagneDrive® II Series

At a Glance

Average Static Torque: 60 inch-lbs. (6.6 N-m)

Material of Construction: A-286 Stainless Steel

Maximum Pressure: Up to 6600 psi @ 650° F
(455 bar @ 343°C)

Applications: Agitator recognized worldwide as a highly efficient method of promoting chemical reactions and catalyst testing among gases, liquids and solids in high pressure autoclaves.

Dispersimax® agitation available for gas dispersion through liquid during mixing

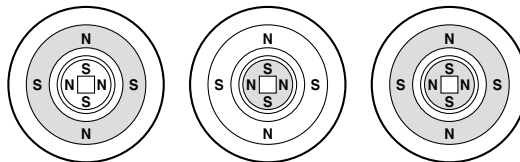

External driver magnets

Encapsulated driver magnet assembly and sealed rotor shaft

Outer magnets are rotated by a motor driven belt thus rotating inner magnets and rotor shaft.

The MagneDrive® Principle



Principle of Operation

MagneDrive II agitators use rare earth magnets, permitting packless mixing at higher speeds in larger vessels and with higher viscosity fluids. Outer drive magnets, rotated by a motor-driven belt, exert powerful attraction on the encapsulated inner magnet assembly. As the outer drive magnets are rotated, the inner magnets are actuated, resulting in rotation of the agitator shaft.

Contamination-free mixing- Packless design eliminates shaft packing and need for lubrication.

Zero leakage to atmosphere- The MagneDrive II is a sealed system, closed to the atmosphere, so even sensitive fluids can be processed safely.

Continuous, high speed operation- No need to shut down in mid-reaction to change failed packing.

Autoclave Engineers 

Division of Snap-tite, Inc.

Features

- Operating pressures as high as 6,600 psi @ 650° F (455 bar @ 343°C).
- Compact design with up to 60 in-lb (6.6 N-m) of static torque.
- Designed for simple disassembly and maintenance. Bearings can be replaced with minimal effort.
- Carbon graphite and Rulon® LR bearings available.
- Various impellers available, contact factory for details.

General Specifications

Base Model	Maximum Pressure at Connection PSI (bar)
1.5002AS06A	6000 (414) @ 850°F (454°C)
1.5002AS06CBD	6600 (454) @ 650°F (343°C)

Maximum Speed: 2000 rpm

Static Torque: 60 inch-lbs (6.6 N-m)

Power at Maximum Speed (2000 rpm): 1.9 HP (1.4 kW)^{2,3}

Material of Construction: A-286 Stainless Steel. Optional materials, including 316 Stainless Steel, titanium, and Hastelloy® C276, are available upon request. For information on additional materials, please consult the factory.

Bearing Material: Purebon® 658RCH⁴ or Rulon® LR

Maximum Temperature at Magnet Zone: 300°F (149°C)⁵

Maximum Temperature at Connection: 650°F (343°C) with Purebon® 658 RCH Bearings

Cover Connection: Collar and gland or threaded housing (see dimension table)

Purge Connection: 1.5002 MagneDrives are provided with a 0.125" (3 mm) tube gas purge connection.

Tachometer Pick-up: Hall effect proximity sensor or Reed switch, which sense internal shaft rpm, is standard.

Shaft and Impeller: 1.5002 MagneDrives are supplied without shafts or impellers, allowing for customizing of the shaft length and impeller style. Drive shaft, supplied separately, is screwed into the MagneDrive encapsulation. Autoclave Engineers offers a wide selection of impellers in a variety of materials, including the Dispersimax™ gas dispersion system. Please consult the factory for more information.

¹ Maximum speeds may be limited by mixing requirements and shaft vibration, including critical speed.

² Motor horsepower should be sized at least 25% higher than the intended application requirement.

³ To determine horsepower at a certain speed, use the formula:

$$hp = \frac{T \times n}{63,025} \quad \text{where: } T = \text{torque in inch-lbs} \\ n = \text{speed in rpm}$$

⁴ Purebon is a registered Trademark of Pure Carbon Company, Inc.

⁵ The magnets are stabilized at 300 °F (149 °C). When the temperature of the magnets exceeds the stabilizing temperature for an extended period, loss of magnetic torque will occur. Some of this loss is reversible and torque will regenerate; however, the problem is avoided by using adequate cooling to limit the magnet temperature to 300 °F (149 °C). A cooling jacket with two NPT connections is provided for water cooling, if necessary. Additional information on cooling requirements can be obtained in the Operation and Maintenance manual.

Supporting Information

Please refer to the following sections of the catalog for complimentary products and additional technical details. See the 1.5002 Ordering Guide on the back cover to configure a drive for your specific application.

1.5002 Drawings

Model	Drawing Number
1.5002AS06A	30A-9340
1.5002AS06CBD	30A-5454

Consult factory for other connection requirements

Dimensional

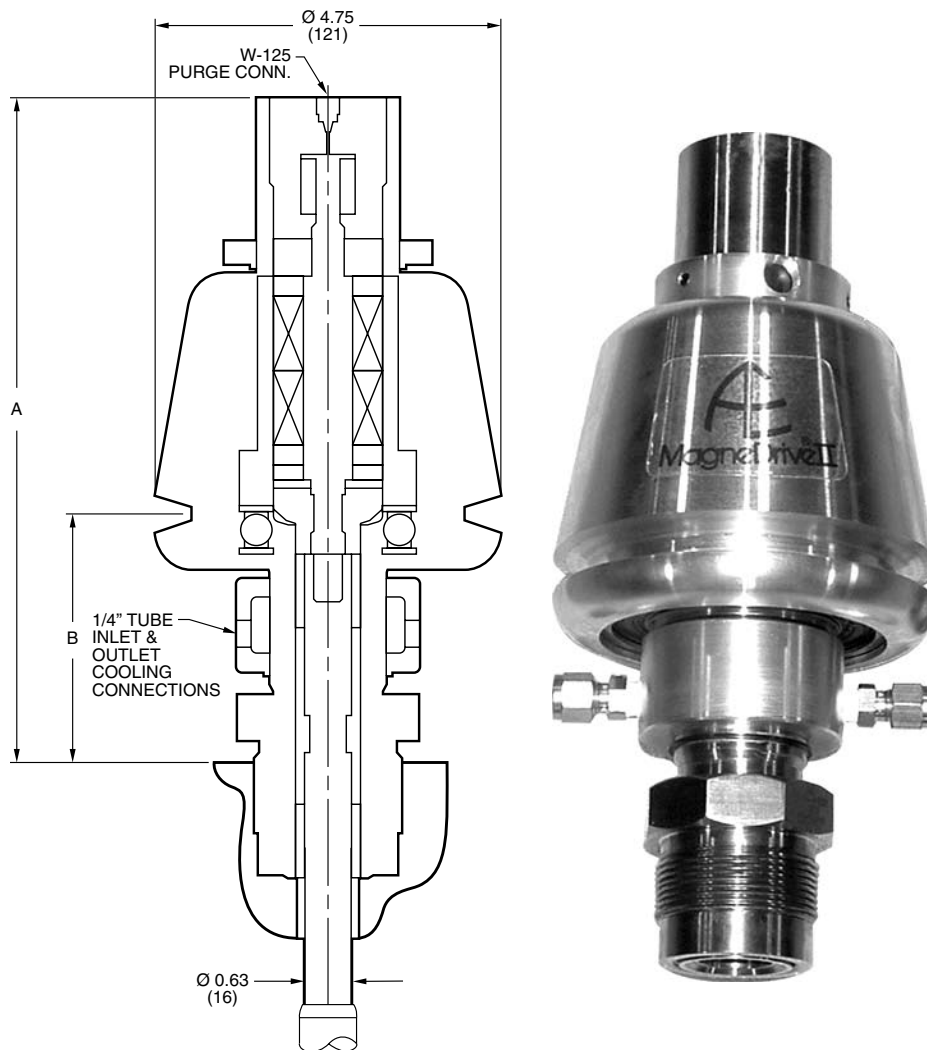

Base Model	A	B	Cover Connection
1.5002AS06A	11.41 (290)	5.84 (148)	10D-0115
1.5002AS06CBD	9.00 (229)	3.38 (86)	10C-2397

inches (mm)

Ordering Guide

1.5002

A A B B C C C D D E F G

AA - Material	
AS	A-286
BB - Pressure	
06	6000 psi (414 bar) or 6600 psi (455 bar)
CCC - Connection	
A	Threaded Housing
CBD	Collar Gland - Large Diameter Shaft
DD - Bearing	
PB	Purebon® 658RCH
RB	Rulon® LR
E - Sensor	
O	None
HS	Hall Effect Proximity Sensor
RS	Reed Switch
F - Top Seal	
KO	Kalrez® O-ring
VO	Viton® O-ring
TS	Teflon/Silicon O-ring
G - Ball Bearing	
PP	Poly Pak Bearing
SL	Standard Lubrication Bearing

Example: 1.5002AS06A-PBHSVO is a 1.5002 series MagneDrive® in Hastelloy® A-286, rated 6000 psi with Purebon® bearings, Hall effect speed sensor, and Viton® O-ring.

Note: Drive shafts and Impellers are not included with MagneDrive®, consult factory for availability.

Purebon® is a registered trademark of Pure Carbon.

Rulon® is a registered trademark of Saint-Gobain.

Hastelloy® is a registered trademark of Haynes International

Viton® is a registered trademark of DuPont Performance Elastomers



Division of Snap-tite, Inc.

8325 Hessinger Drive
 Erie, Pennsylvania 16509-4679
 PH: 814-860-5700 FAX: 814-860-5811
 e-mail: aeclave_sales@snap-tite.com
www.autoclaveengineers.com

ISO-9001 Certified



06-0016SE-0109

! WARNING !

FAILURE OR IMPROPER SELECTION OR IMPROPER USE OF THE PRODUCTS AND/OR SYSTEMS DESCRIBED HEREIN OR RELATED ITEMS CAN CAUSE DEATH, PERSONAL INJURY AND/OR PROPERTY DAMAGE.
 This document and other information from Snap-tite, Inc., its subsidiaries and authorized distributors, provides product and/or system options for further investigation by users having technical expertise. It is important that you analyze all aspects of your application and review the information concerning the product or system in the current product catalog. Due to the variety of operation conditions and applications for these products or systems, the user, through its own analysis and testing, is solely responsible for making the final selection of the products and systems and assuring that all performance, safety and warning requirements of the application are met. The products described herein, including without limitation, product features, specifications, designs, availability and pricing, are subject to change by Snap-tite, Inc. and its subsidiaries at any time without notice.

Bulletin AGT-MAG1.5002

The World Leading Provider of High Pressure Equipment for Research and Industry since 1945!